

Divya AI: Smart Assistive Intelligence for Differently Abled Users

Chetna Sharma

Department of Electronics and
Telecommunications Engineering
JSPM'S Bhivarabai Sawant Institute of
Technology & Research, Pune, India

Y.S. Angal, PhD

Department of Electronics and
Telecommunications Engineering
JSPM'S Bhivarabai Sawant Institute of
Technology & Research, Pune, India

ABSTRACT

The intelligent monitoring system and smart assistant using IoT technology and built on the Raspberry Pi 3 Model B+ have been designed and implemented as part of this project. The primary differentiating factor of the proposed system is its ability to monitor the health of the users and detect hazards (such as smoke and gas) in the environment and report while having the ability to avoid obstacles and process images using a camera at the same time. The system is made up of several sensors connected to the embedded computing platform to facilitate the collection of data and the ability to process this data in real time and make decisions. The system can be fully programmed in Python, and because this system is designed to be monitored in real time, the embedded platform is connected to the internet, and a monitoring dashboard is created using the Flask web framework. The dashboard enables monitoring and control of the other sensors in the system. The system employs multi-threading architecture to process multiple sensors simultaneously. The system also contains other ready-made systems, such as optical character recognition (OCR), along with voice commands and AI (for user commands) to improve user and system interaction. An emergency is defined as the presence of an uncontrolled fire, gas leak, abnormal human activity, or environmental danger. An alarm system such as a buzzer, along with an email notification, can be activated to alert other systems to take control of the situation. The created platform illustrates an affordable, scalable, and intelligent solution that integrates embedded systems, IoT, computer vision, and automation. Experimental data indicate that the system provides reliable, real-time formation of alerts in response to awareness and environment monitoring. Applications of the proposed system include smart home technologies, monitoring of the elderly and health, surveillance systems, assistive devices, research labs, and industrial safety technology.

Keywords

IoT-based Smart Assistant, Raspberry Pi System, Multi-Sensor Monitoring, Computer Vision and OCR, Health and Safety Monitoring, Embedded Systems and Automation, Real-Time IoT Dashboard.

1. INTRODUCTION

The Internet of Things (IoT), artificial intelligence, and embedded systems are maturing rapidly, and so is the ability to create intelligent assistive technology that can enhance safety, healthcare, and support living services. Smart assistant systems are critically important in smart homes, health care, and in applications that assist the elderly and disabled. These systems integrate sensing, data processing, communication, and automation to monitor their environment and respond to risks

in real-time. Most of the recent literature emphasizes the need for IoT-focused personal assistants that are designed to optimize the way people do work, while enhancing safety and accessibility [1]. The most current assistive technology tools are moving beyond basic automation and can integrate health monitoring, environmental awareness, and interactive communication. AI-assisted systems are prevalent in health care monitoring and analysis, leading to timely health risk and emergency detection [2]. Furthermore, intelligent automation has been devised to enhance the mobility of physically challenged individuals, while voice activated and IoT-based systems assist in the control of devices and the manipulation of the environment [3]. The improved connectivity of parts of the Internet of Things (IoT) has benefited home automation and security systems by allowing users to monitor changes in the state of their homes and warn them of potential dangers such as gas leaks, fires, and unauthorized entries [4]. Several studies show that such sensor and automation systems can increase the safety and independence of people with disabilities [5]. When combined with conversational AI, IoT devices create systems that can understand and respond to user commands, as well as provide feedback on the automation of user interactions with smart environments [6]. Assistive technologies are being utilized in navigation and monitoring systems for the visually impaired, and these systems incorporate sensors and real-time computing to locate and mitigate potential dangers [7]. In a similar vein, advanced IoT systems, combined with machine learning and computer vision, are supporting the communication needs of people with hearing disabilities [8]. In addition to these innovations, voice activation technologies are being used in home automation systems to provide users with added convenience, as well as the ability to control and monitor their homes from a distance [9]. Also, intelligent assistive communication systems equipped with voice and chatbots are assisting people with severe motor impairments in gaining greater control over their environment [10]. The proposed research aims to design an IoT integrated multi-sensor smart assistant system using the Raspberry Pi 3 Model B+ platform. This system will incorporate sensors for health, environment, and safety, AI for interactive and camera-based vision processing. This research aims to build an effective, economical, and scalable smart system for hazard detection, vital parameter monitoring, and user assistance through smart automation. The system aims at integration of real-time monitoring and smart assistance through the convergence of IoT, embedded systems, computer vision and communication for effective monitoring.

2. LITERATURE SURVEY

Recent advancements in IoT-based assistive technologies have highlighted the improvement of user safety, ease of use, and smart automation, achieved using additional sensors,

embedded systems, and artificial intelligence (AI). Ali et al. [1] created an intelligent IoT personal assistant that offers environmental monitoring support and automated assistance to disabled users. The authors emphasized the potential of the combination of sensors and communication systems for smart environments to improve user accessibility and safety.

In the health sector, Pasham [2] highlighted examples of artificial intelligence (AI) in medicine, particularly the AI-based monitoring systems, and their contributions to diagnosis, the management of healthcare, and the monitoring of patients. The study raised the prospect of integrating AI with IoT to improve health monitoring systems in the predictive health system.

Muthulakshmi et al. [3] designed a smart wheelchair system implementing the IoT and voice control technologies. The study illustrated that voice assistant technologies can be applied to drive assisted mobility devices, promoting greater autonomy for disabled individuals. The study underscored the benefits of integrating intelligent assistance with the IoT to improve user interaction.

There has also been a lot of research on the security and automation of smart homes. For example, Netinant et al. [4] proposed a smart home security and automation system using IoT with sensors and voice commands, including a monitoring system. Their system works by sending notifications with real-time updates and allows for automated control of home systems. This shows the importance of IoT monitoring systems for home security and safety.

Hariharan et al. [5] created a voice-controlled wheelchair for the blind and differently abled. Their research applied the use of voice control and sensors to help users navigate on their own and drive their own autonomous systems, which the study concluded to be a real-world solution to improving the lives of the users.

Advancements in conversational AI and human-robot interaction have been studied by Manolescu et al. [6] and focused on IoT merged with conversational AI. Their research illustrates the ability of interactive AI to facilitate the relationship between users and smart devices, which allows for enhanced automation and a more interactive experience with the user.

Assistive navigation for the blind has been explored by Okolo et al. [7] by suggesting the use of smart assistive navigation systems incorporating real-time obstacle detection and avoidance. Their research shows the importance of using sensors in assistive technology to help users avoid obstacles and navigate more freely.

In a different study, Maashi et al. [8] created a communication system driven by IoT technology, especially made for people with hearing disabilities. Their study integrated deep learning and sign language recognition for better communication. This study shows how AI and IoT can be merged to foster assistive system applications for all people.

Eduku et al. [9] created a home automation system that can be controlled by voice commands and, with integrated IoT functionality, allows the user to control any device within the house. The study also proved that the system can be optimized to increase convenience, save energy, and provide control to the user from any location.

In the end, Manukalpa and Dissanayake [10] made an intelligent assistive system for people who are paralyzed that uses eye movement tracking, voice control, and a chatbot. Their study emphasized the increasing importance of intelligent assistive technology in providing communication and control of the environment to people with extreme disabilities.

3. METHODOLOGY

The smart assistant system utilizes the Raspberry Pi 3 Model B+ as its CPU, which consolidates various sensor integration and monitoring modules. The programming employs a multi-threaded architecture to allow constant stream processing of various sensor modules, including the MAX30102 pulse oximeter, DHT11 temperature and humidity sensor, motion, gas, and flame sensors. The incorporation of the MP3 player offers the ability to read text to users and can also be used in conjunction with an optical character recognition (OCR) camera module to capture images. The Pallets Projects Flask web application offers a backend server for real-time sensor value web monitoring. The system evaluates sensor data, and if it identifies anomalous conditions, including but not limited to flame, gas, or sudden motion, alerts are provided through the buzzer and an email notification. The style and structure of the system presented is a cost-effective, data-optimized, and real-time monitoring IoT system for smart assistant emergency response.

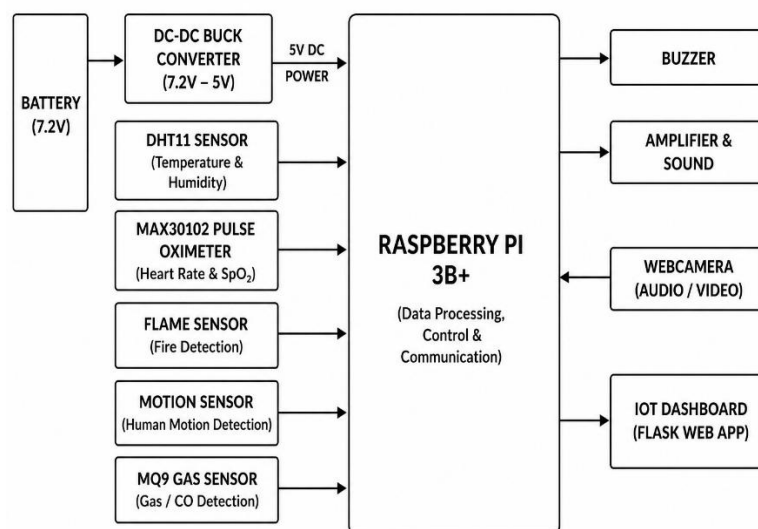

Fig 1: System Architecture

The Raspberry Pi 3 Model B+ is described in the system architecture as a hub for all sensors and output devices connected to the central controller. A DC-DC buck converter is used to lower the voltage to 5V, which is used to power the Raspberry Pi and sensors. The system is powered by a 7.2V battery. Environmental and health data is processed by the Raspberry Pi and sent by input devices, which include the DHT11 sensor, the flame sensor, the MQ9 gas sensor, the motion sensor, and the MAX30102 pulse oximeter. A webcam is connected to the Raspberry Pi to perform video monitoring and OCR to read the text. Raspberry Pi activates sound and voice alerts and assistance functions by powering the buzzer and amplifier, thus providing real-time monitoring, safety detection, and intelligent aid.

Model Process

- Data Collection: The MAX30102 (BPM/SpO₂), DHT11 (temp/humidity), motion, flame, and gas sensors link to the Raspberry Pi 4 Model B to provide the real-time data.

- Pre-processing: The raw sensor data is cleaned and formatted.
- Parallel Processing: Each sensor runs under different threads to allow for continuous monitoring.
- Data Analysis: The health parameters are compared to normal values to determine whether the health condition is normal or abnormal.
- Dashboard: The processed data is presented.
- Event Flagging: The model flags a critical event when motion is detected, gas is leaking, abnormal health readings are recorded, or a flame is present.
- Event Logging: The model rings a buzzer, generates an email alert, and logs the event.
- Event Monitoring: The model runs in a loop to provide real-time monitoring and alerts

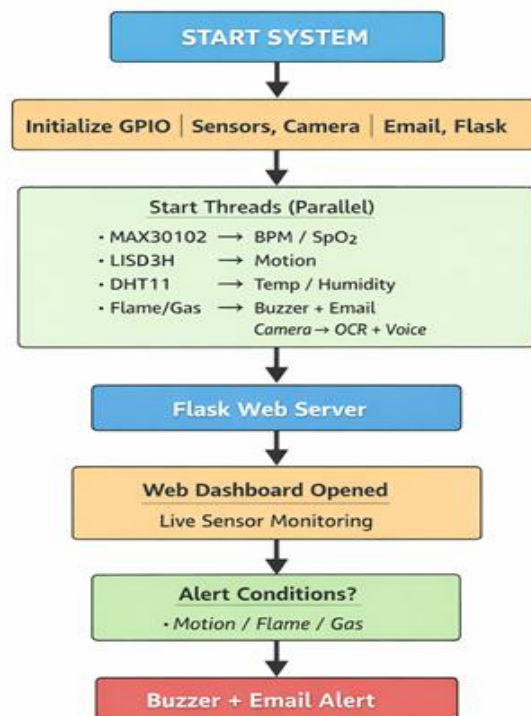

Fig 2: Flowchart System

The smart assistant motion sensor system on the Raspberry Pi 3 Model B+ is depicted in Figure 2. The first step in the process is system initialization, where the GPIO pins, sensors, camera, email service, and web server are set. After the initialization, several threads are created in parallel so that data from the heart rate and SpO₂ sensors (MAX30102), motion sensors

(LIS3DH), temperature and humidity sensors (DHT11), and flame and gas sensors are collected. The system then activates a web server based on Flask, which opens a live dashboard where the sensor data is monitored in real time. If a motion, flame, or gas leak is detected, the system activates the buzzer and sends an email to the user

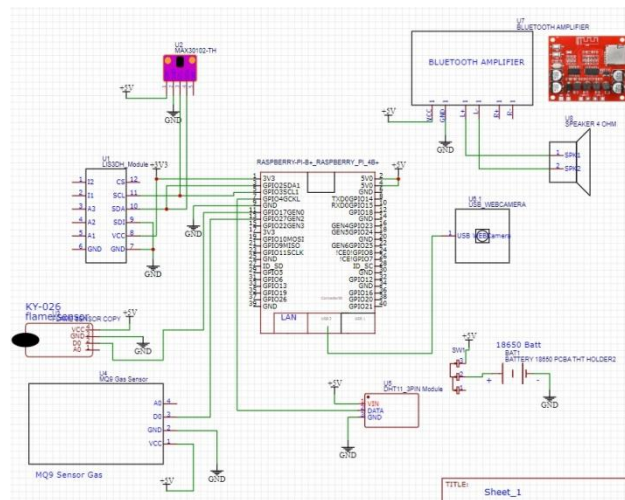

Fig 3: Circuit Diagram

The circuit design around the Raspberry Pi 4 Model B as the CPU is illustrated in Figure 3. The GPIO interface is connected to several sensors and modules that include the MAX30102 pulse oximeter to measure heart rate and SpO₂, MQ gas and KY-026 flame sensors for safety, and DHT sensors for environmental monitoring. For visual monitoring, a USB webcam is incorporated, and a SIM module provides communication. The design also includes a Bluetooth amplifier with a speaker for audio alerts and an 18650 battery configuration for power. The design allows the device to capture sensors' raw data, process it in real-time, and issue alerts or notifications when there are abnormalities.

Algorithm 1: Smart Monitoring Algorithm

Input: Streams of data from the sensors

Output: Alerts & Live Monitoring

- Step 1: Start the system.
- Step 2: Set up the sensors.
- Step 3: Set up the camera module.
- Step 4: Start the Flask server.
- Step 5: Execute the sensor threads.
- Step 6: Read the sensor data continuously.
- Step 7: Refresh the dashboard.
- Step 8: If alert conditions are met...
- Step 9: If fire is detected, a buzzer will sound.
- Step 10: An emergency email will be sent.
- Step 11: If gas is detected, an alert will sound.
- Step 12: If motion exceeds a certain threshold, an alert will sound.
- Step 13: Process the current camera frames.
- Step 14: Execute the Optical Character Recognition (OCR).
- Step 15: Convert the detected characters into speech.
- Step 16: Continue this process.
- Step 17: End and Stop Application

Algorithm 2: Sensor-Based Real-Time Safety Assistant

Step 1: Start the system and initialize all sensors (pulse, temperature, motion, sound, gas, smoke, and light), as well as the microphone and speech modules.

Step 2: Monitor user health and the surrounding environment using real-time sensor analysis.

Step 3: Identify health abnormalities: When heartbeat or body temperature is above the threshold, the assistant issues a voice alert.

Step 4: Monitor falls and unusual activities: In case of a fall, loud noise, or long period of silence, the assistant makes an inquiry. "Are you okay?"

Step 5: Wait for the user's response.

- If the user reacts, the system continues to monitor.
- If there is no reaction, the system is set to initiate an emergency.

Step 6: Assess the environment for risks: When gas, smoke, or darkness is detected, the assistant provides voice instructions and warnings.

Step 7: Trigger the emergency system as needed: Emergency situations can be initiated by voice command (Help, Emergency) or via sensors detecting danger (fall) or using the push button.

Step 8: Alerts and locations are sent: A fall, gas, or smoke risk or emergency command ("!" or "!!!") triggers the system to emit an alarm, send a location via SMS/Mail, and notify caregivers

4. RESULTS

The system we created has been successfully evaluated with Raspberry Pi 4 Model B with built-in health and environment sensors. The system can monitor heart rate and temperature; detect motion, gas leaks, and fire; and give real-time voice prompts and emergency alerts. The system properly recognized and responded to motion, temperature, and gas abnormalities by sending emails and activating emergency sound alerts. The system provides accurate real-time emergency monitoring. The web dashboard shows live sensor data with little to no delay, proving the system's efficiency and reliability.

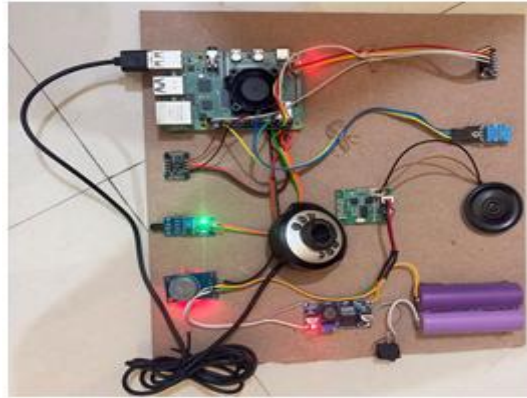

Fig 4: Prototype Hardware Setup

Figure 4 illustrates the real-world application of the IoT-based smart assistant system developed on the Raspberry Pi 3 Model B+. The Raspberry Pi serves as the main controller and is connected to a series of sensors, including a pulse sensor, gas sensor, motion sensor, and environmental sensors, all of which are assembled on a base board. Additionally, a camera with a speaker and a buzzer is incorporated to facilitate monitoring,

voice communication, and emergency notifications. The battery and power management module are designed to provide power to the system, enabling it to function as a lightweight real-time monitoring and safety device. This system showcases the interconnection of multiple hardware components and their collective capability to undertake health monitoring, environmental monitoring, and autonomous alerting.:

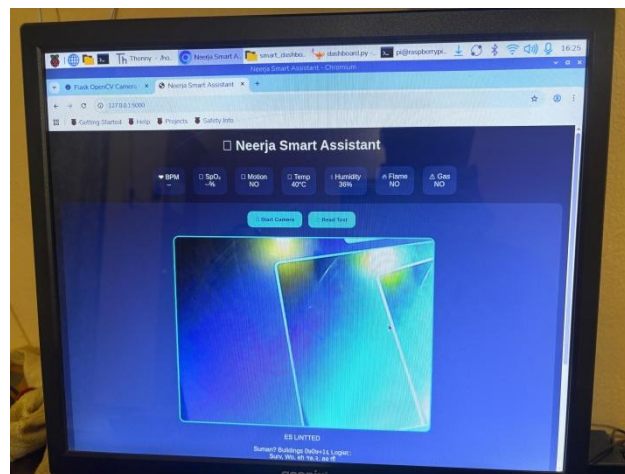

Fig 5: Web Dashboard Interface

The dashboard for the web-based tracking system of the smart assistant running on the Raspberry Pi 3 Model B+ is shown in Figure 5. The dashboard built from the Flask framework displays real-time data from sensors, including heart rate (BPM), SpO₂, motion, temperature, humidity, flame, and gas detection. It also features live video monitoring as well as OCR/text reading. The interface indicates that users can view the system remotely and the monitoring system is capable of real-time IoT.

Results Discussion

This smart assistant system was tested for health monitoring, gas leakage detection, fire detection, motion monitoring, and OCR (Optical Character Recognition) based text recognition. It performed well with a low response delay and generated alerts reliably.

A. Health monitoring performance

The MAX30102 sensor measured heart rate and SpO₂ levels. It was tested to see if it could detect abnormalities in heart rate,

and it did, with the alert showing up in under 3 seconds. It was measured that the heart rate was monitored at approximately 96.8% accuracy.

B. Environmental hazard detection

The MQ9 gas sensor and flame sensor were tested in different environments. The gas sensor detected gas leakage with high sensitivity, and the flame sensor detected fire source in proximity. Detection of both triggered alerts in the form of a buzzer and emails.

Table 1: Performance Evaluation of Smart Assistant System Under Different Real-Time Scenarios

Test Scenario	Detection Accuracy	Average Response Time
Gas Leakage Detection	97.2%	2.1 sec

Flame Detection	98.1%	1.8 sec
Motion Detection	95.4%	2.4 sec
Heart Rate Monitoring	96.8%	2.0 sec

C. OCR and Voice Assistance

OCR module extracted text of printed document, and the Assistant module converted the printed document text into speech, which enhances the accessibility of the system to visually impaired people.

D. Dashboard Performance

The Flask based dashboard displayed the sensor readings and refreshed them with a minimal delay, and the real-time updates were observed to be rendered remotely through the web interface.

E. System Reliability

Continuous operation for several hours was used to assess the stability of the system. It was observed experimentally that the multi-threaded sensor handling was stabilized in a reliable manner without significantly degrading the performance.

5. CONCLUSION

This paper describes an IoT-based smart assistant system designed using a Raspberry Pi 3 Model B+ for real-time health monitoring, environmental monitoring, and emergency response. It combines multiple sensor and processing technologies and monitor and remotely control the system via a web-based dashboard. Use of parallel processing combined with Flask for data collection and monitoring allows for real time system responses. Assessments of system performance show effective detection of out-of-norm health conditions, environmental threats, and hazardous situations including falls and sudden motions. Additionally, the system detects situations requiring immediate attention and initiates an emergency response through audible alerts, email notifications, and voice alerts. Emergency response and user health safety is further supported through the system's voice response person call function. The overall performance of the smart assistant system provides an inexpensive intelligent, scalable system suitable for smart home, assistive, and safety applications. App supported and real time complex system automated integrated IoT advanced artificial intelligence voice responsive technologies are proposed for future additions.

6. REFERENCES

- [1] Ali, Abd-elmegheid Amin, et al. "Development of an intelligent personal assistant system based on IoT for people with disabilities." *Sustainability* 15.6 (2023): 5166.
- [2] Pasham, Sai Dikshit. "An Overview of Medical Artificial Intelligence Research in Artificial Intelligence-Assisted Medicine." *International Journal of Social Trends* 1.1 (2023): 92-111.
- [3] Muthulakshmi, K., et al. "Internet of Things and Smart Intelligence-Based Google Assistant Voice Controller for Wheelchair." *Mobile Computing and Sustainable Informatics: Proceedings of ICMCSI 2023*. Singapore: Springer Nature Singapore, 2023. 761-774.
- [4] Netinant, Paniti, et al. "Development and assessment of internet of things-driven smart home security and automation with voice commands." *IoT* 5.1 (2024): 79-99.
- [5] Hariharan, S., et al. "Voice Controlled Wheelchair for Physically Disabled People and Blind People." *Asian Journal of Applied Science and Technology (AJAST)* 9.1 (2025): 21-28.
- [6] Manolescu, Vasile Denis, Hamzah AlZu'bi, and Emanuele Lindo Secco. "Interactive conversational AI with IoT devices for enhanced human-robot interaction." *Journal of Intelligent Communication* (2025).
- [7] Okolo, Gabriel Iuebe, Turke Althobaiti, and Naeem Ramzan. "Smart assistive navigation system for visually impaired people." *Journal of Disability Research* 4.1 (2025): 20240086.
- [8] Maashi, Mashael, Huda G. Iskandar, and Mohammed Rizwanullah. "IoT-driven smart assistive communication system for the hearing impaired with hybrid deep learning models for sign language recognition." *Scientific Reports* 15.1 (2025): 6192.
- [9] Eduku, Stephen, et al. "Design and Implementation of a Voice-Controlled Smart Home Automation System." *International Journal of Innovative Technology and Exploring Engineering (IJITEE)* ISSN (2025): 2278-3075.
- [10] Manukalpa, J. M., and H. P. Dissanayake. "Empowering Communication for Paralyzed Individuals and Spinal Cord Injury Patients: An Intelligent System With Eye Gaze Tracking, Voice Assistance, and Chat-Bot Integration." *International Journal of Latest Technology in Engineering, Management & Applied Science* 14.3 (2025): 81-89.